

# Air booster ABP Series

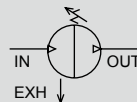

JIS symbol



- F.R.L
- F (Filtr)
- R (Reg)
- L (Lub)
- PresSW
- Shutoff
- SlowStart
- FimResistFR
- Oil-ProHR
- MedPresFR
- No Cu/ PTFE FRL
- Outdrs FR
- F.R.L (Related)
- CompFRL
- LgFRL
- PrecsR
- VacF/R
- Clean FR
- ElecPneur
- AirBoost
- SpdContr
- Silncr
- CheckV/ other
- Jnt/tube
- AirUnt
- PrecsCompn
- Mech/ ElecPresSw
- ContactSW
- AirSens
- PresSW Cool
- AirFloSens/ Contr
- WaterRtSens
- TotAirSys (Total Air)
- TotAirSys (Gamma)
- RefrDry
- DesicDry
- HiPolymDry
- MainFiltr
- Dischrg etc
- Ending

## Functions

● Primary pressure flowing from IN passes through the check valve on the IN side, and flows into the booster chambers A and B. The primary pressure passes through the pressure adjustment section and switching valve, and flows into the driving chamber A. The piston moves to the left due to the pressure of the driving chamber A. Air in booster chamber A is compressed, passes through the check valve on the OUT side, and goes to the OUT side.

● When the piston reaches the stroke end, the changeover switch will be pushed, causing compressed air to be supplied to the switching valve pilot chamber and causing the switching valve to change over. Then the air in drive chamber A is exhausted, and the air is delivered to drive chamber B.

● Therefore, the piston moves to the right and air in booster chamber B is compressed, passes through the check valve at the OUT side and moves OUT.

● Boosting on the OUT side is compressed if the operations above are repeated. Feedback pressure is transmitted to the pressure adjustment section due to the OUT side pressure, and boosting is continued until the pressure adjustment spring pressure is balanced.

## Specifications

1 MPa ≈ 145.0 psi, 1 MPa = 10 bar

Descriptions	ABP
Working fluid	Compressed air
Max. working pressure MPa	0.99 (≈140 psi, 9.9 bar)
Min. working pressure MPa	0.2 (≈29 psi, 2 bar)
Set pressure MPa	From a primary pressure of +0.1 MPa to twice the primary pressure (max. 0.99 MPa)
Proof pressure MPa	1.5 (≈220 psi, 15 bar)
Flow rate m <sup>3</sup> /min(ANR)	Refer to the flow characteristics in the graph on the right
Boosting ratio	Max. twice (or equivalent)
Ambient temperature °C	0 (32°F) to 50 (122°F) (no freezing)
Lubrication	Not required (use turbine oil class 1 ISO VG32 if necessary for lubrication)
Port size	Rc1/2
Weight kg	4.6
Durability	5 million (nominal)

## How to order



Air booster

### A OUT port position

Blank	Same side as IN port
D	Bottom (direct connection to air tank)
L	Back side of IN port

### B Option

G	Pressure gauge
S	Silencer
B	Foot bracket

Note) Option G (pressure gauge) is installed onto air booster at shipment. B (foot bracket) and S (silencer) are enclosed products.

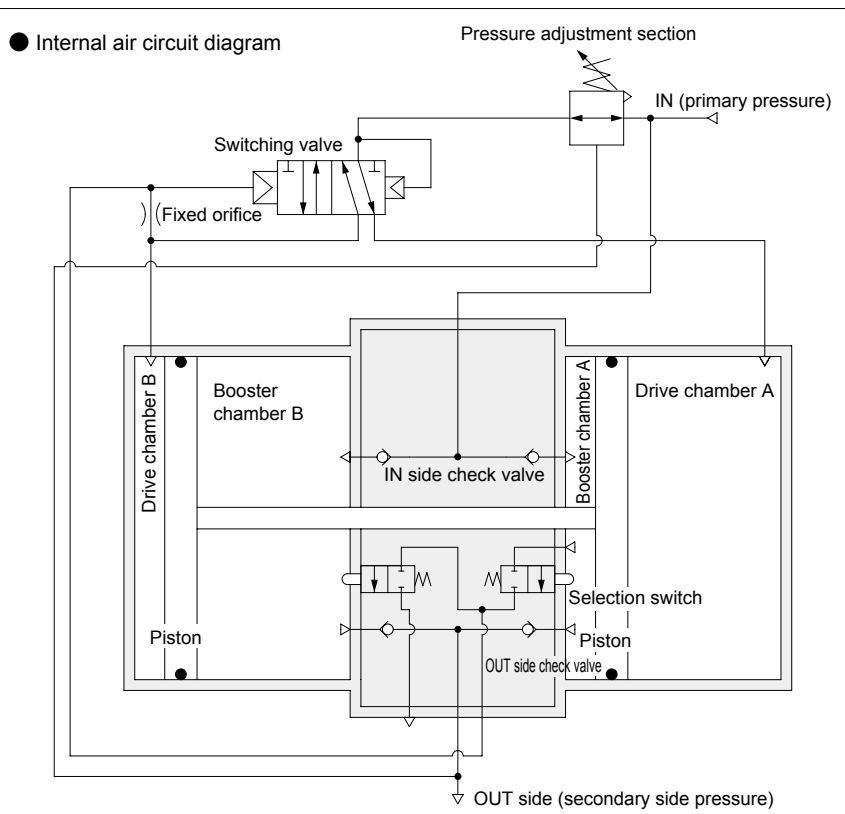

- F.R.L
- F (Filtr)
- R (Reg)
- L (Lub)
- PresSW
- Shutoff
- SlowStart
- FimResistFR
- Oil-ProhR
- MedPresFR
- No Cu/PTFE FRL
- Outdrs FR
- F.R.L (Related)
- CompFRL
- LgFRL
- PrecsR
- VacF/R
- Clean FR
- ElecPneuR
- AirBoost**
- SpdContr
- Silncr
- CheckV/other
- Jnt/tube
- AirUnt
- PrecsCompn
- Mech/ElecPresSw
- ContactSW
- AirSens
- PresSW Cool
- AirFloSens/Contr
- WaterRISens
- TotAirSys (Total Air)
- TotAirSys (Gamma)
- RefrDry
- DesicDry
- HiPolymDry
- MainFiltr
- Dischrg etc
- Ending

**Flow characteristics** (with AT-24 air tank, twice the pressure)

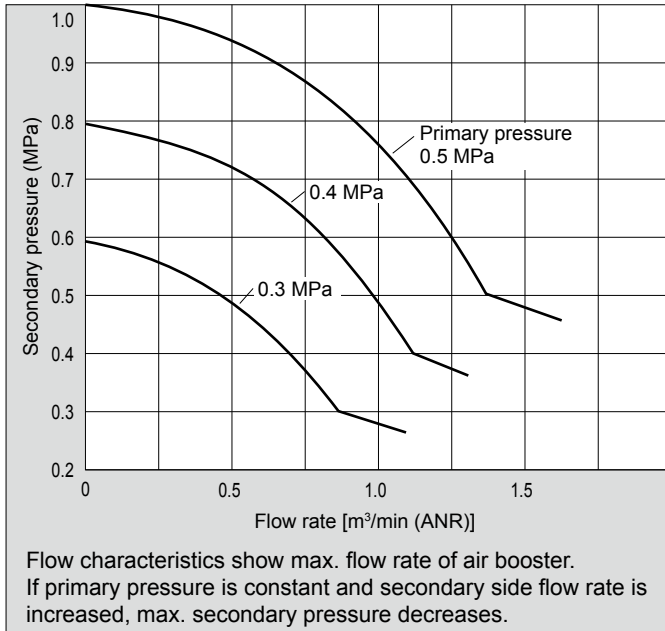

**Pressure characteristics** (Setting: 0.69 MPa primary pressure, 0.97 MPa secondary pressure, 0.02 m³/min ANR flow rate)

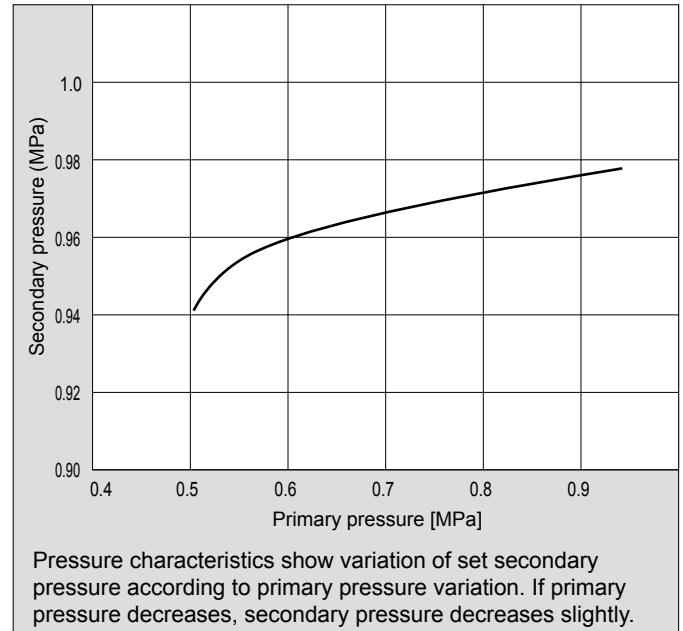

Note) Air booster needs approx. twice secondary side flow rate (max.) for primary side due to structure. Confirm that the instantaneous flow rate is within the curve.

**Filling characteristics**

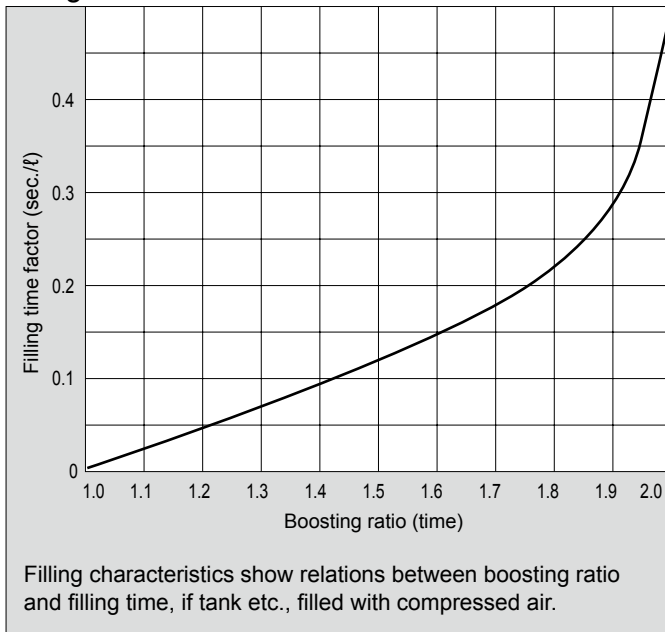

The time required to fill the tank with air can be calculated as follows. With the primary side pressure  $P_0$ , inner tank pressure before filling  $P_1$ , inner tank pressure after filling  $P_2$ , pre-filling ratio between primary side pressure and inner tank pressure  $k_1$ , and post-filling ratio between primary side pressure and inner tank pressure  $k_2$ , the formula will be  $k_1 = \frac{P_1}{P_0}$ ,  $k_2 = \frac{P_2}{P_0}$ . Calculate  $k_1$  and  $k_2$ , find the filling time factors  $t_1$  and  $t_2$  at the boosting ratio points  $k_1$  and  $k_2$  in the graph and substitute the values into  $t = (t_2 - t_1) A$  to obtain the filling time  $t$  of the tank capacity  $A$  (ℓ).

**Pulsation**

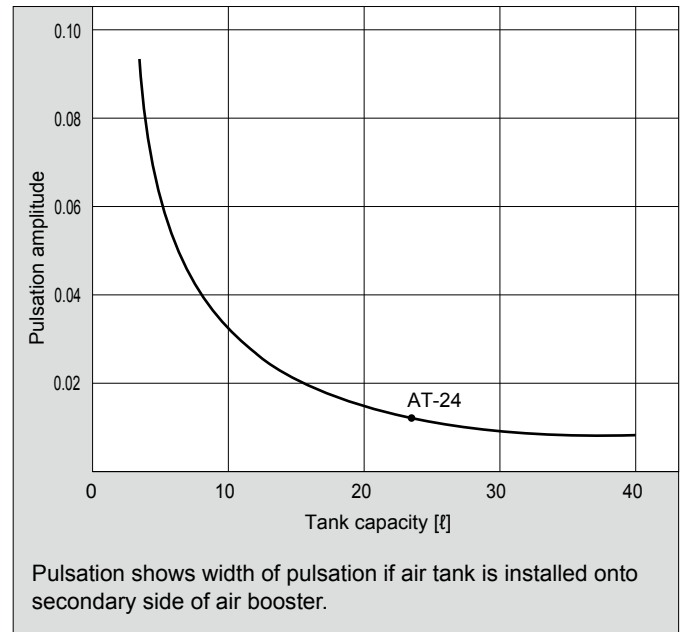

Formula for air booster operational cycle

$$N = \frac{Q \times 10^3}{7.55P + 0.76}$$

N: Operational cycle  
Q: Required flow rate [m³/min (ANR)]  
P: Primary side pressure [MPa]

Formula for air booster service life

Nominal life of operational cycle is 5 million times

$$T = \frac{5,000,000}{N \times 60}$$

T: Service life (hours)

The characteristics above are typical examples, not guaranteed values.

## F.R.L Internal structure

- F (Filtr)
- R (Reg)
- L (Lub)
- PresSW
- Shutoff
- SlowStart
- FimResistFR
- Oil-ProhR
- MedPresFR
- No Cu/  
PTFE FRL
- Outdrs FR
- F.R.L  
(Related)
- CompFRL
- LgFRL
- PrecsR
- VacFR
- Clean FR
- ElecPneuR
- AirBoost**
- SpdContr
- Silncr
- CheckV/  
other
- Jnt/tube
- AirUnt
- PrecsCompn
- Mech/  
ElecPresSw
- ContactSW
- AirSens
- PresSW  
Cool
- AirFloSens/  
Contr
- WaterRtSens
- TotAirSys  
(Total Air)
- TotAirSys  
(Gamma)
- RefrDry
- DesicDry
- HiPolymDry
- MainFiltr
- Dischrg  
etc
- Ending

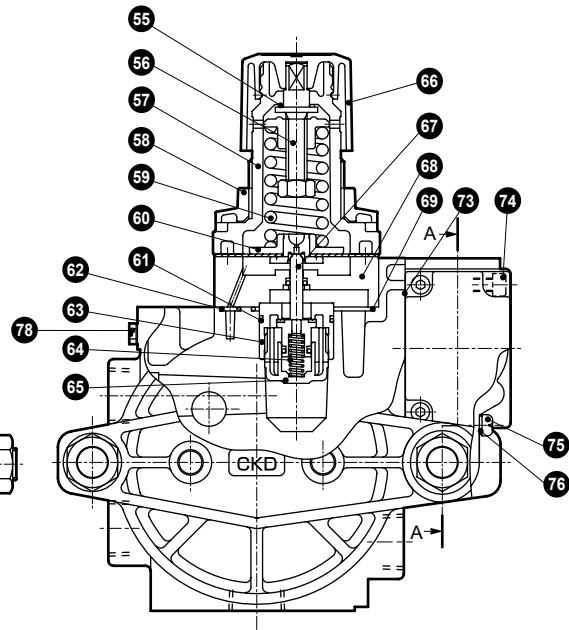
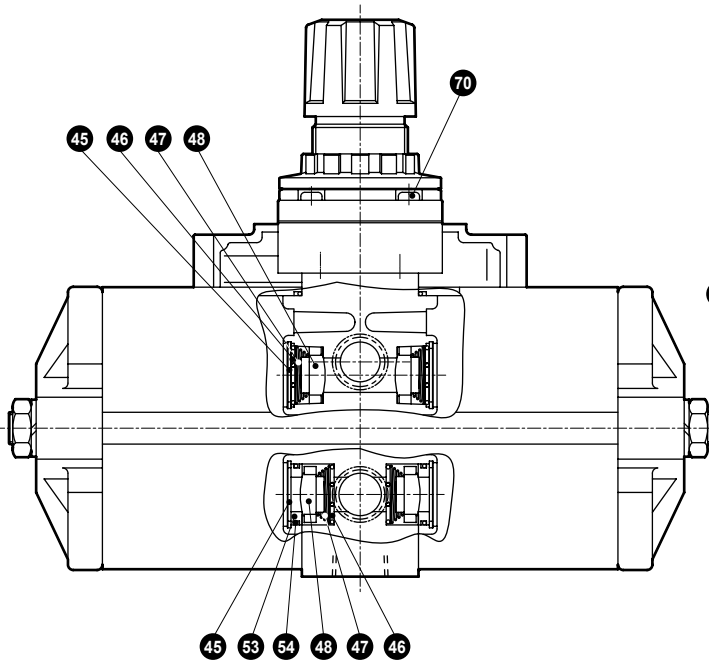
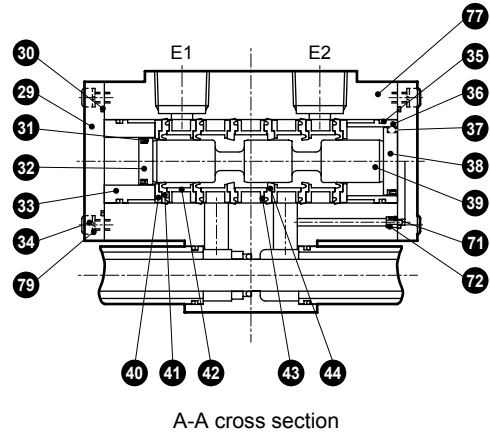
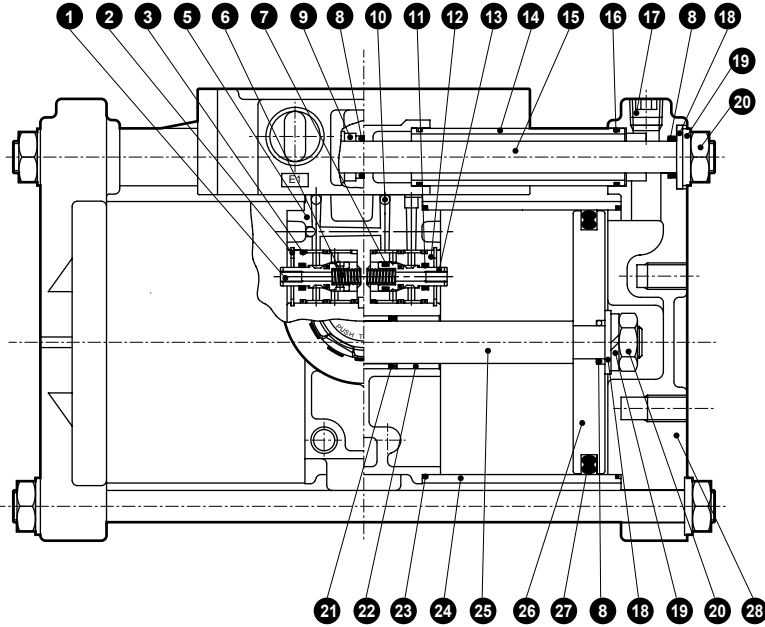

## Parts list

No.	Part name	Material	Quantity	No.	Part name	Material	Quantity
1	Valve bar (A)	Stainless steel	1	41	Soft packing	Urethane rubber	4
2	C type snap ring for hole	Stainless steel	2	42	Spacer	Aluminum alloy	4
3	O-ring	Nitrile rubber	5	43	Spacer	Polyacetal resin	1
5	Body block assembly	Aluminum alloy	1	44	Soft packing	Urethane rubber	2
6	Spring	Stainless steel	2	45	C type snap ring for hole	Stainless steel	4
7	O-ring	Nitrile rubber	1	46	Spring seat	Stainless steel	4
8	O-ring	Nitrile rubber	5	47	Spring	Stainless steel	4
9	Spacer	Stainless steel	1	48	Check valve	Nitrile rubber	4
10	Steel ball	Steel	3	53	Valve seat	Aluminum alloy	2
11	Packing	Nitrile rubber	2	54	O-ring	Nitrile rubber	1
12	Detection valve body	Copper alloy	2	55	Slip ring	Polyacetal resin	4
13	Bar (B)	Stainless steel	1	56	Adjusting assembly		1
14	Pipe	Stainless steel	2	57	Cover	PBT resin	1
15	Tie rod	Steel	2	58	Mounting nut	Polyacetal resin	1
16	O-ring	Nitrile rubber	4	59	Adjusting spring	Steel	1
17	Hexagon socket head cap plug	Steel	2	60	Diaphragm assembly		1
18	Plain washer	Steel	4	61	O-ring	Nitrile rubber	1
19	Spring washer	Steel	6	62	O-ring	Nitrile rubber	1
20	Hexagon nut	Steel	6	63	Valve seat	Copper alloy	1
21	MY packing	Nitrile rubber	2	64	Bottom spring	Stainless steel	1
22	Rod metal	Oil impregnated bearing alloy	3	65	Stud	Polyacetal resin	1
23	O-ring	Nitrile rubber	4	66	Knob	Polyacetal resin	1
24	Cylinder tube	Aluminum alloy	2	67	Valve assembly		1
25	Piston rod	Steel	1	68	Regulator body assembly		1
26	Piston	Aluminum alloy	2	69	O-ring	Nitrile rubber	1
27	Piston packing	Nitrile rubber	2	70	Cross-recessed tapping screw	Steel	4
28	Head cover	Aluminum alloy	2	71	Fixed orifice	Copper alloy	1
29	Cap	Aluminum alloy	2	72	O-ring	Nitrile rubber	1
30	Gasket	Nitrile rubber	2	73	Master valve gasket	Nitrile rubber	1
31	Lip packing	Nitrile rubber	1	74	Hexagon socket head cap screw	Steel	2
32	Piston	Polyacetal resin	1	75	Cross-recessed pan head machine screw	Steel	1
33	Cylinder	Aluminum alloy	1	76	Gasket	Nitrile rubber	1
34	Hexagon socket head cap screw	Steel	8	77	Valve body	Aluminum alloy	1
35	O-ring	Nitrile rubber	2	78	Plug	Copper alloy	1
36	Cylinder	Aluminum alloy	1	79	Spring washer	Steel	8
37	Lip packing	Nitrile rubber	1				
38	Piston	Polyacetal resin	1				
39	Spool	Aluminum alloy	1				
40	Stopper	Polyacetal resin	2				

## Single unit repair parts and options list

Part name	Model No.	Part No.	Remarks
Changeover switch packing set	ABP-K1	1 × 1, 3 × 5, 6 × 2, 11 × 2, 12 × 2, 13 × 1, 7 × 1	
Cylinder packing set	ABP-K2	8 × 5, 16 × 4, 21 × 2, 23 × 4, 27 × 2	
Switching valve piston assembly	ABP-K3	31 × 1, 32 × 1, 37 × 1, 38 × 1	
Switching valve seal assembly	ABP-K4	40 × 2, 41 × 4, 42 × 4, 43 × 1, 44 × 2	
Diaphragm assembly	ABP-K6	60 × 1	
Pressure adjustment section valve assembly	ABP-K7	61 × 1, 62 × 1, 67 × 1, 69 × 1	
Check valve assembly	ABP-K8	48 × 4, 53 × 2, 54 × 2	
Bracket	ABP-B		Qty per unit
Pressure gauge	ABP-GAUGE		Pressure gauge x 1
Silencer	SLW-15A		Silencer x 1

F.R.L
F (Filtr)
R (Reg)
L (Lub)
PresSW
Shutoff
SlowStart
FmResistFR
Oil-ProhR
MedPresFR
No Cu/ PTFE FRL
Outdrs FR
F.R.L (Related)
CompFRL
LgFRL
PrecsR
VacF/R
Clean FR
ElecPneuR
AirBoost
SpdContr
Silncr
CheckV/ other
Jnt/tube
AirUnt
PrecsCompn
Mech/ ElecPresSw
ContactSW
AirSens
PresSW Cool
AirFloSens/ Contr
WaterRtSens
TotAirSys (Total Air)
TotAirSys (Gamma)
RefrDry
DesicDry
HiPolymDry
MainFiltr
Dischrg etc
Ending

F.R.L
F (Filtr)
R (Reg)
L (Lub)
PresSW
Shutoff
SlowStart
FimResistFR
Oil-ProhrR
MedPresFR
No Cu/ PTFE FRL
Outdrs FR
F.R.L (Related)
CompFRL
LgFRL
PrecsR
VacF/R
Clean FR
ElecPneuR
AirBoost
SpdContr
Silncr
CheckV/ other
Jnt/tube
AirUnt
PrecsCompn
Mech/ ElecPresSw
ContactSW
AirSens
PresSW Cool
AirFloSens/ Contr
WaterRtSens
TotAirSys (Total Air)
TotAirSys (Gamma)
RefrDry
DesicDry
HiPolymDry
MainFiltr
Dischrg etc
Ending

## Dimensions



### ● ABP-12

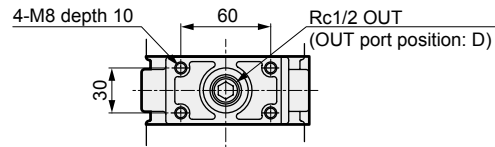
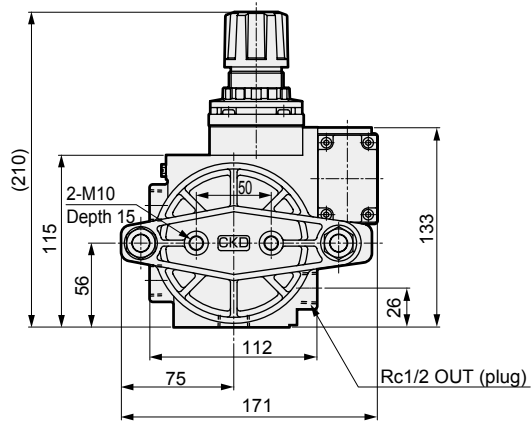
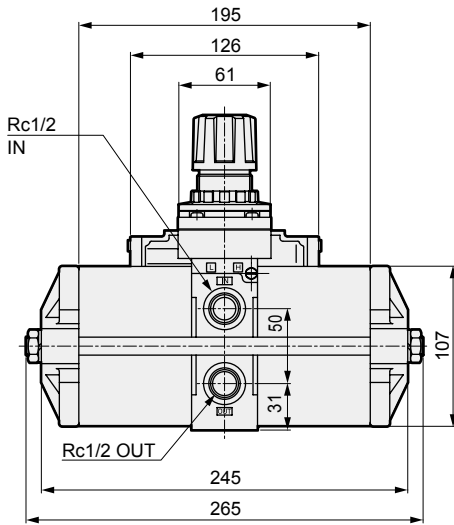
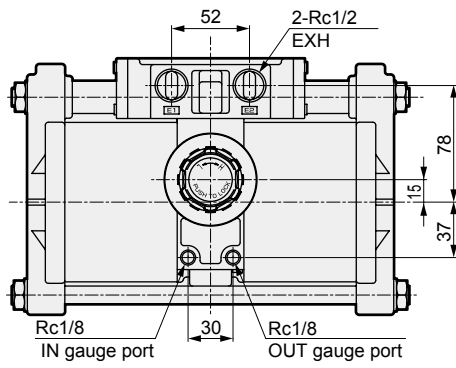

## Optional dimensions

### ● When mounting the bracket (ABP-B)

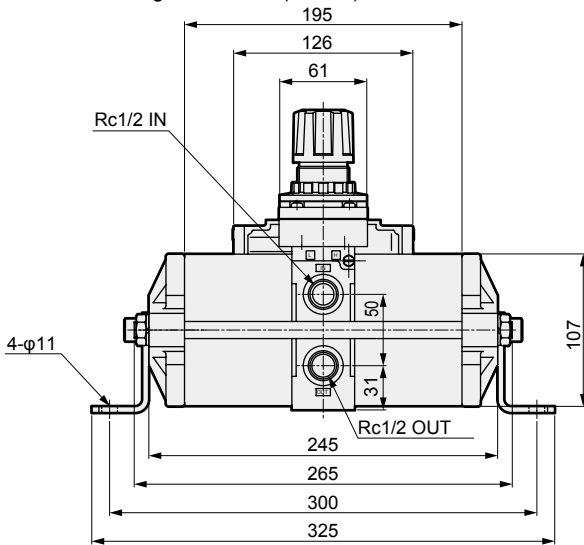

Weight: 792 g (excluding ABP body and including bracket/bolt/spring washer)

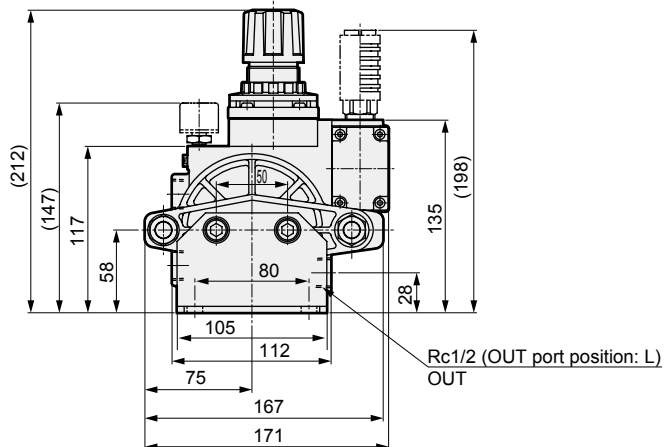

### ● Pressure gauge (ABP-GAUGE)

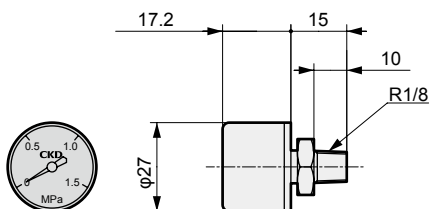

Weight: 32g

### ● Silencer (SLW-15A)

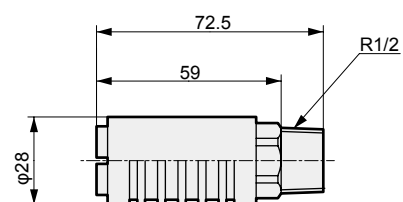

Weight: 21g