

SCM7B



Module Dimensions and Pinouts

The following mechanical drawing is useful if designing circuit boards to mount the SCM7B modules. Many sockets are available which accept the mounting pins. As an example, AMP Inc. provides a socket with part number 50865-5.

The captive nut for the 4-40 mounting screw can be obtained from PEM (Penn Engineering and Manufacturing), part number KSF2-440.

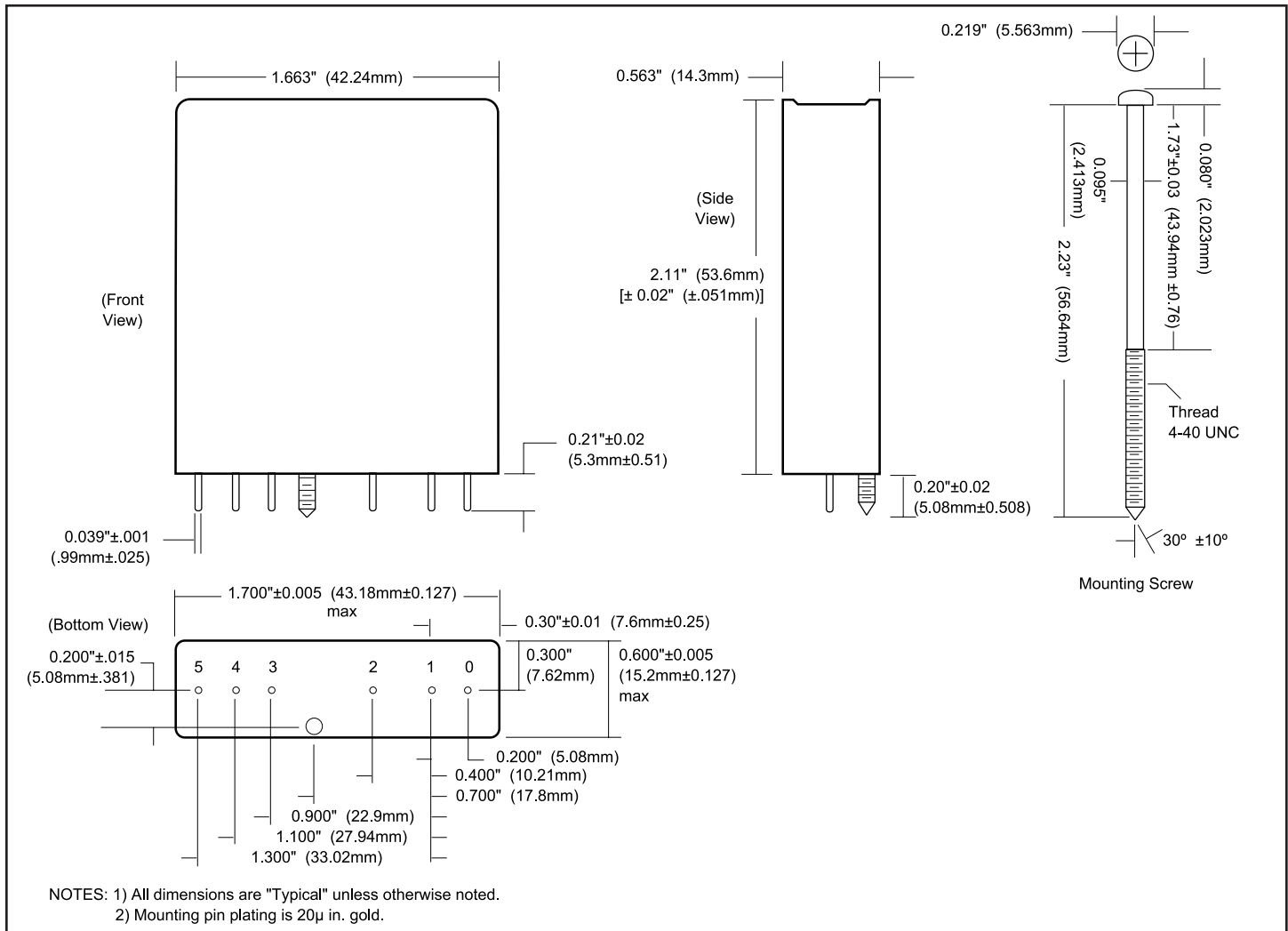

Figure 1: SCM7B Module Dimensions

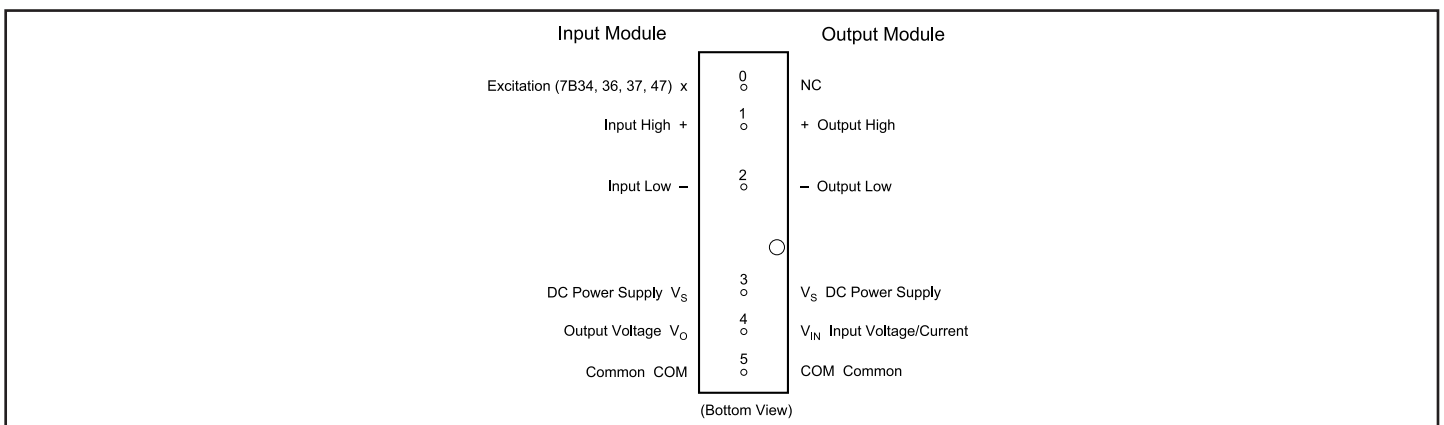

Figure 2: SCM7B Pinouts

Accessories for SCM7B Analog Modules

SCM7BXEV

Description

The SCM7BXEV (Figures 1 and 2) is a single channel backpanel that can accept any of the SCM7B analog modules. It is meant to be used primarily for module evaluation. Unlike multiple channel backpanels, the single high-level system output (or input) signal is routed to all channel pins on the system interface DB25 connector. The backpanel contains four standoffs to allow mounting, using a #6 or smaller screw.

System Side - Power

Using the "V+" supply input, the power supply voltage can be as little as +14VDC. If +15VDC is available, it is recommended that the supply be connected between the "V+A" or "V+B" connections and "COM"; this will protect the module against accidental supply reversal. Using both these connections with two power supplies enables redundant operation. It is also recommended that a diode transient absorber be installed to reduce power supply transient events from degrading system performance. An "accessory" location, between the supply and common lines, is provided for this purpose. The backpanel is fused at 1/4 Amp for module protection.

System Side - Signal

The SCM7BXEV uses either the SCM7BXCA01 (DB25 to 26-pin adapter cable) and SCM7BXCA004-XX (26-pin to 26-pin interface cable), or the SCM7BXCA02 (DB25 to DB25 interface cable), depending on system requirements.

Field Side - Signal

On the field side, a temperature sensor is mounted underneath the field side terminal block to provide cold junction compensation for thermocouple modules, and a current-to-voltage conversion resistor (P/N SCM7BXR1) socketing location is provided (supplied with SCM7B33 modules). Field connections are terminated with three screw terminals.

Specifications

Operating Temperature	-40°C to +85°C
Relative Humidity	95% Noncondensing
Interface Connector:	
Field	high density screw clamp, 10-24 AWG
System	DB25 (male) with 4-40 screwlocks and high density screw clamp, 10-24 AWG

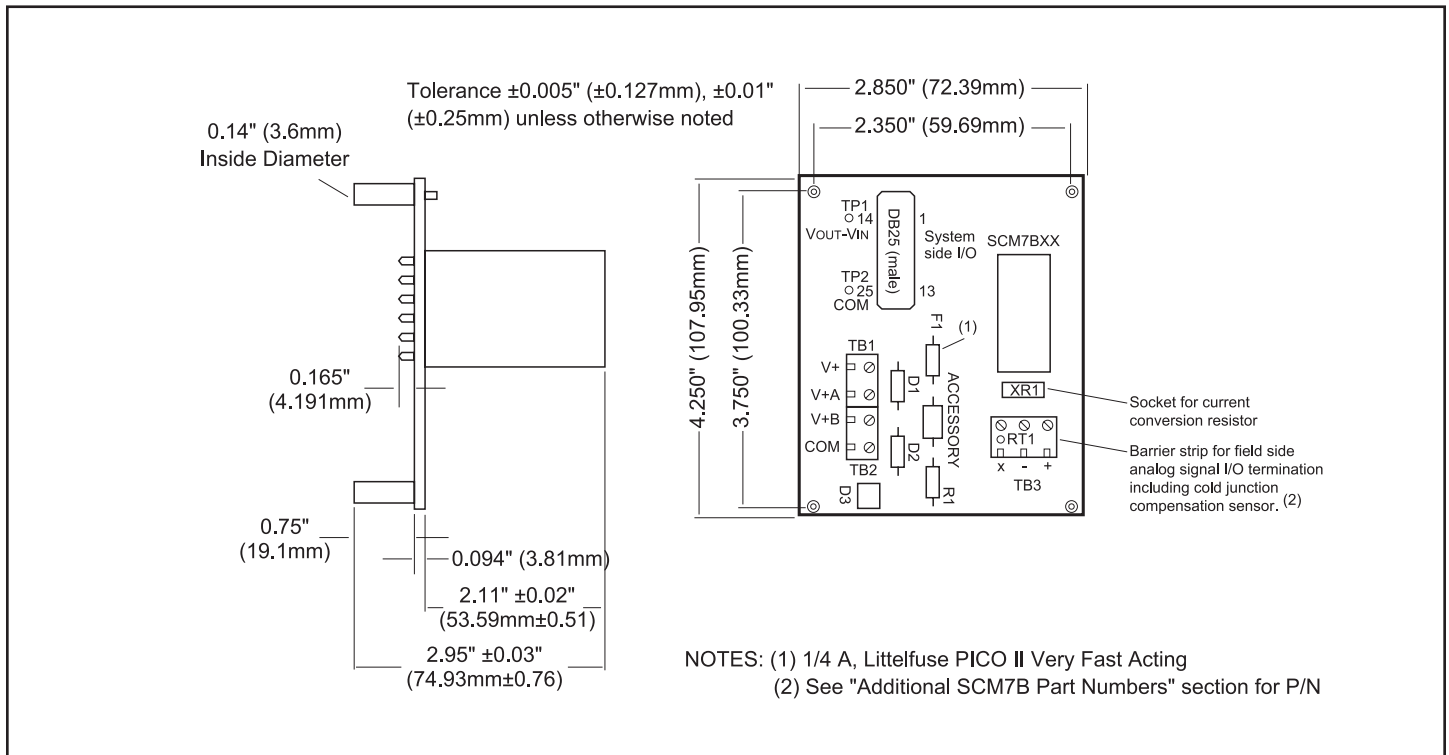

Figure 1: SCM7BXEV Dimensions

SCM7B



NOTE: ALL CHANNELS COMMON THIS MODEL

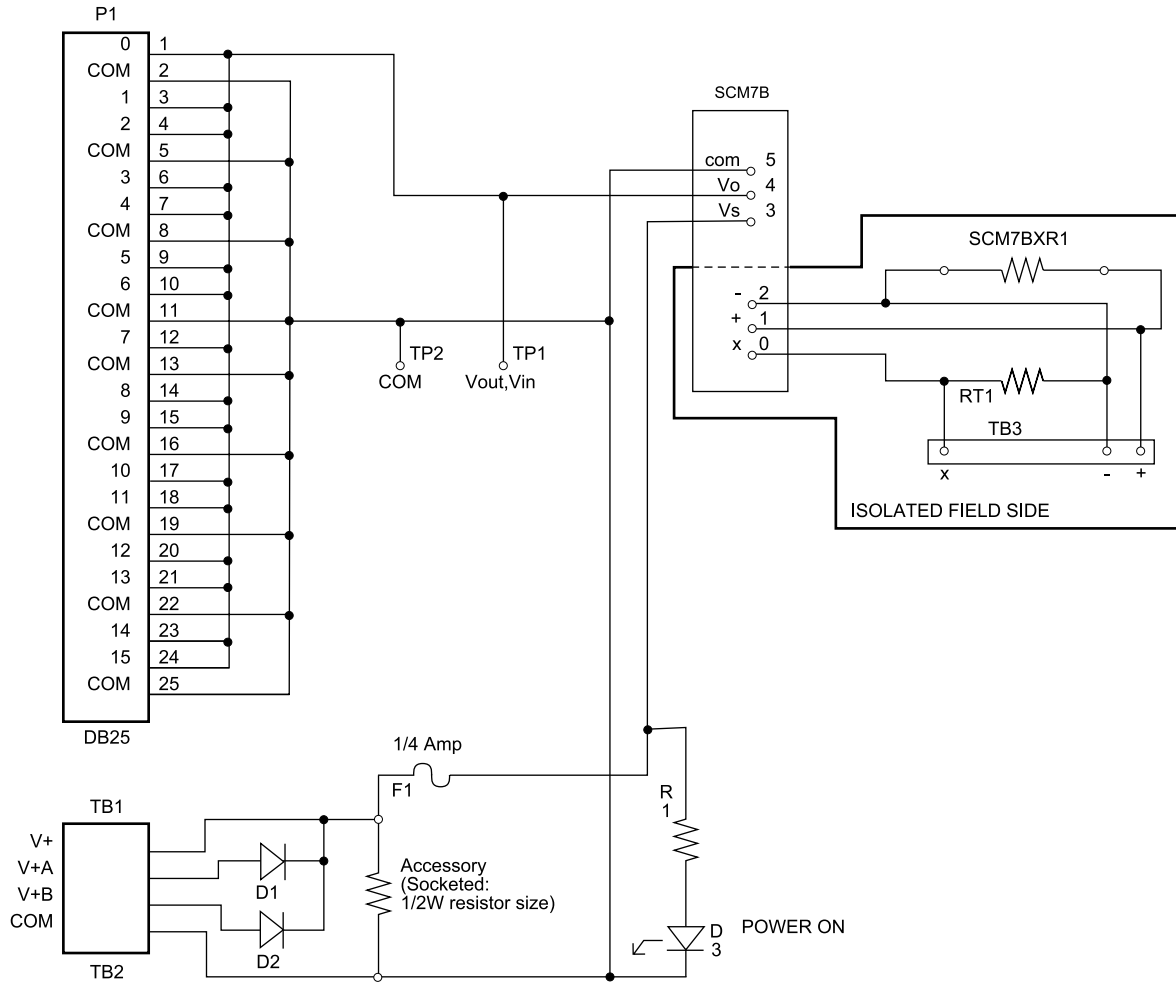

Figure 2: SCM7BxEV Sb ematic Diagram



SCM7BP01/SCM7BP02

Backpanel

Description

The SCM7BP01 (Figure 3) and SCM7BP02 (Figure 4) are 1 and 2 channel backpanels. Unlike other backpanels available, both the system and field side sides have screw terminal connectors able to accept discrete wire (10-24 AWG). The backpanels can be ordered with standoffs to allow mounting, using a #6 or smaller screw, or with DIN rail mounting hardware.

System Side - Power

Both backpanels accept 14-35VDC between "V+" and "COM" using a screw terminal (10-24 AWG) block. No reverse supply diodes are provided with this model, but both are fused at 1/4 Amp (01) or 1/2 Amp (02) for module protection.

Field Side - Signal

On the field side, a temperature sensor is mounted underneath the field side terminal block to provide cold junction compensation for thermocouple modules, and a current-to-voltage conversion resistor (P/N SCM7BXR1) socket location is provided (supplied with SCM7B33 modules).

Specifications

Operating Temperature	-40°C to +85°C
Relative Humidity	95% Noncondensing
Interface Connector:	
Field	high density screw clamp, 10-24 AWG
System	high density screw clamp, 10-24 AWG
Isolation:	
Input-to-Output	1500Vrms continuous, max
Channel-to-Channel	1500Vrms continuous, max

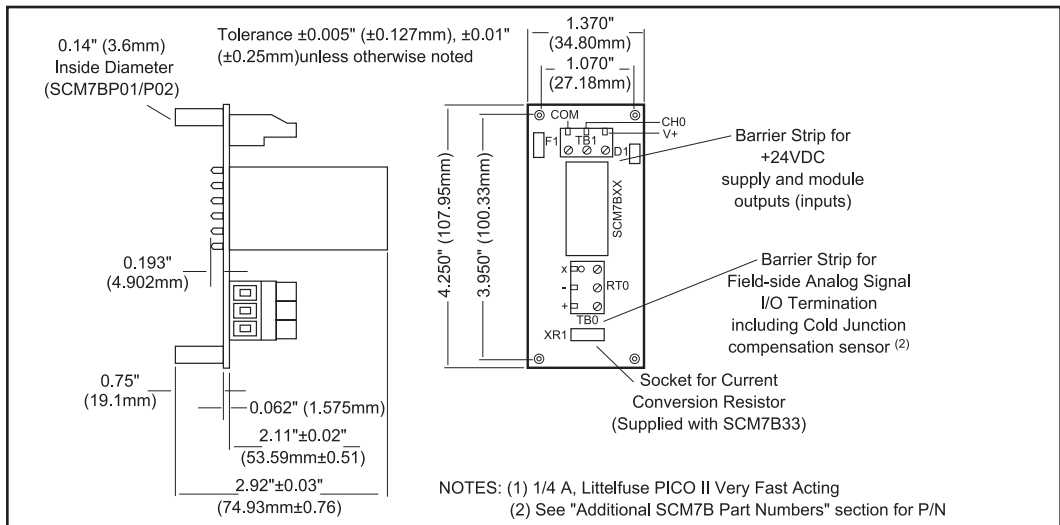

Figure 3: SCM7BP01 Dimensions

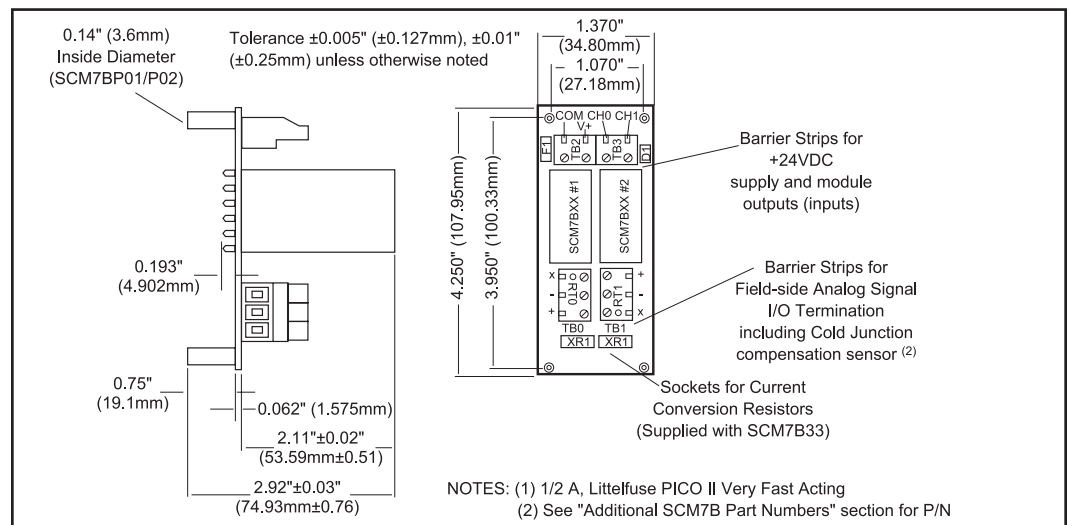

Figure 4: SCM7BP02 Dimensions

SCM7BP01-DIN/SCM7BP02-DIN

Panels & DIN Rail Mounting Accessories



Description

The SCM7BP01 and SCM7BP02 are single and dual channel mounting panels for the SCM7B modules. Both have options for standoffs or DIN rail mounting.

The following accessories are required for DIN rail mounting one SCM7BP01 or SCM7BP02 panel (Figure 5):

Qty	Model	Description
1	SCMXBEFE	Base element with snap foot
2	SCMXSE	Side element

The following accessories are required for DIN rail mounting two or more SCM7BP01-4 or SCM7BP02-4 panels:

Qty	Model	Description
2	SCMXBEFE	Base element with snap foot
2	SCMXSE	Side element
(# panels) - 2	SCMXBE	Base element without snap foot
(4 x (# panels))-4	SCMXVS	Connection pins

The following DIN rail styles are available. Specify length in meters (-XX).

- SCMXRAIL1-XX DIN EN 50022-35x7.5 (slotted steel)
- SCMXRAIL2-XX DIN EN 50035-G32 (slotted steel)
- SCMXRAIL3-XX DIN EN 50022-35x15 (slotted steel)

Ordering Information

Part Number	Description
SCM7BP01	Single channel backpanel with standoffs for mounting.
SCM7BP01-4	Single channel backpanel. No mounting hardware included.
SCM7BP01-DIN	Single channel backpanel with DIN rail mounting hardware. Shipped fully assembled.
SCM7BP02	Dual channel backpanel with standoffs for mounting.
SCM7BP02-4	Dual channel backpanel. No mounting hardware included.
SCM7BP02-DIN	Dual channel backpanel with DIN rail mounting hardware. Shipped fully assembled.

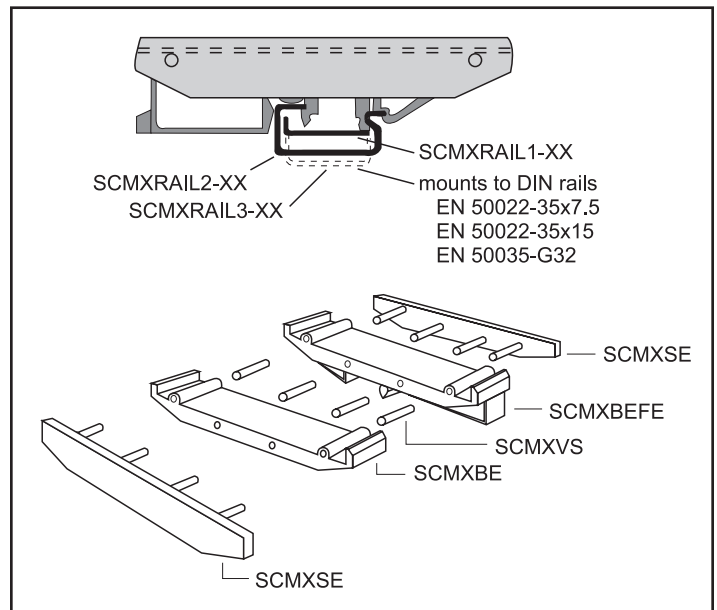

Figure 5: DIN Rail Mounting Elements

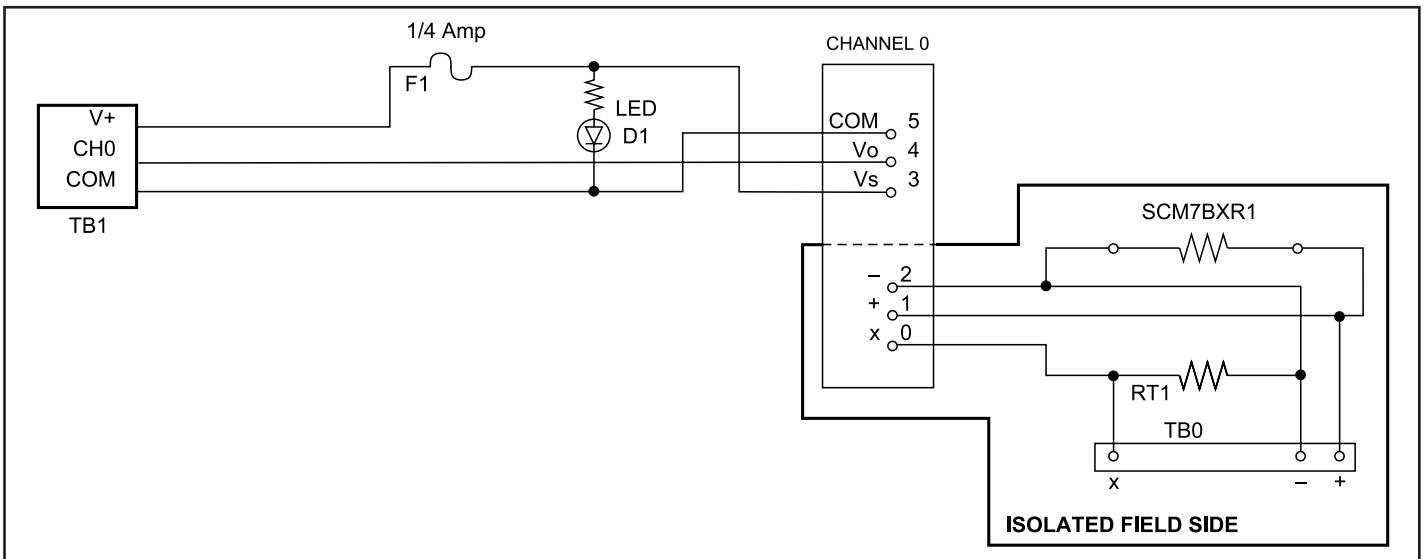

Figure 6: SCM7BP01 (-DIN) Schematic Diagram

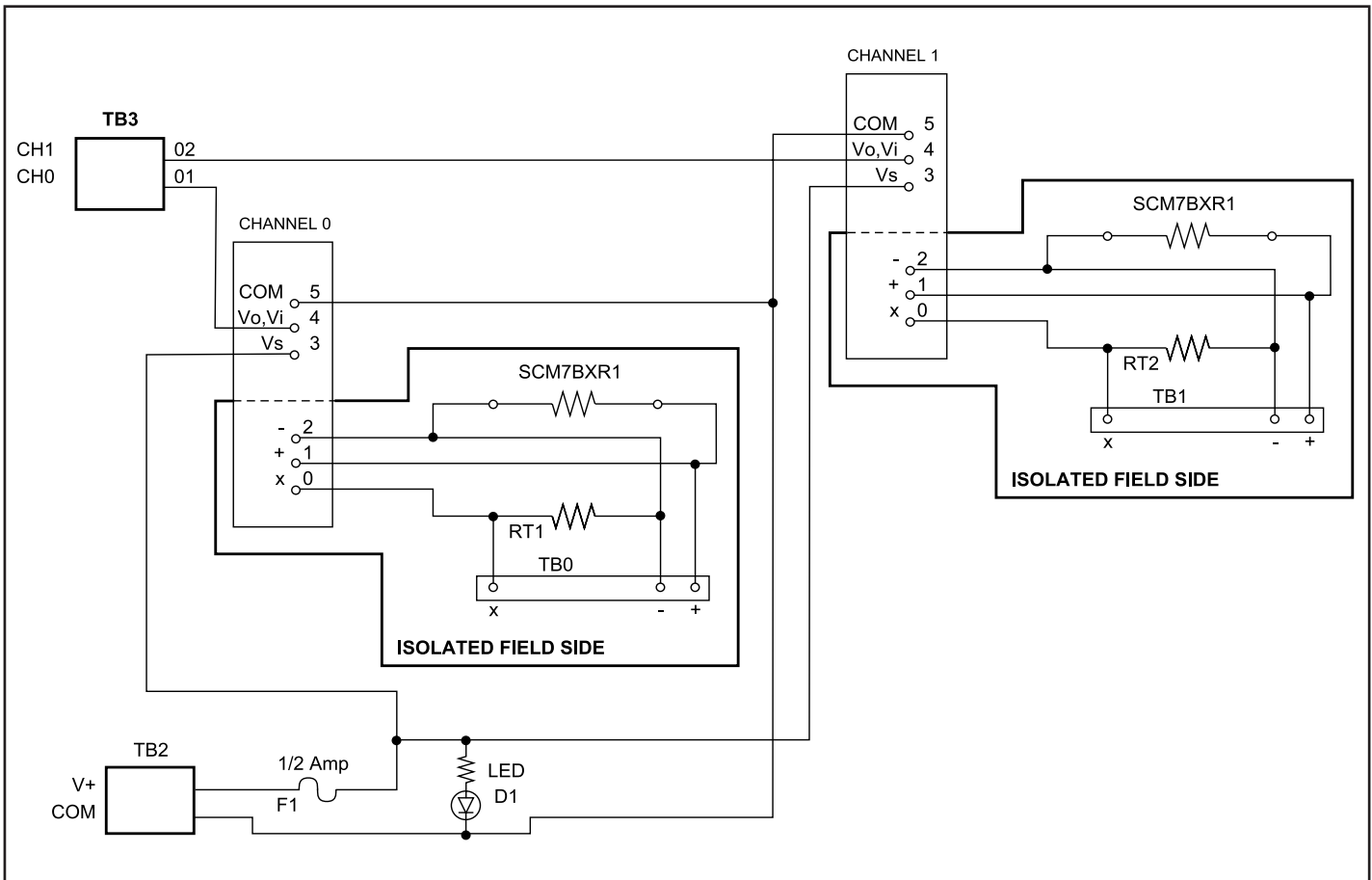

Figure 7: SCM7BP02 (-DIN) Schematic Diagram

SCM7BP04(-DIN)/SCM7BP08(-DIN)/SCM7BP16(-DIN)



Backpanels

Description

The SCM7BP04, SCM7BP08, and SCM7BP16 (see Figures 8-11) are 4, 8, & 16 channel backpanels that can accept any of the SCM7B analog modules. All three of these backpanels can either be rack mounted using Dataforth's 19-inch rack P/N SCMXRK-002 (using the provided 3mm screws), or directly mounted to a surface using #6 or smaller screws. The SCM7BP04-DIN, SCM7BP08-DIN, and SCM7BP16-DIN are identical to the SCM7BP04, SCM7BP08, and SCM7BP16, but with DIN rail mounting clips attached instead of standoffs. These brackets allow the backpanels to be mounted on either EN 50022-35 x 7.5 (35 x 15) or EN 50035-G32 type DIN rails.

System Side - Power

Using the "V+" power supply input, the power supply voltage can be as little as +14VDC. If +15VDC is available, it is recommended that the supply be connected between the "V+A" or "V+B" connections and "COM"; this will protect the modules against accidental supply reversal. Using both these connections with two power supplies enables redundant power supply operation. It is also recommended that a diode transient absorber be installed to reduce power supply transient events from degrading system performance. An "accessory" location, between the supply and common lines, is provided for this purpose. A system side grounding #10-32 stud is also provided for use if desired. All backpanels are fused according to channel count, allowing 1/4 Amp per channel.

System Side - Signal

Two system interface DB25 connectors are used, to enable using both input and output modules simultaneously, or to route the signal from an input module backplane to an output module backplane. These backpanels use either the SCM7BXCA01 (DB25 to 26-pin adapter cable) and SCM7XCA004-XX (26-pin to 26-pin interface cable), or the SCM7BXCA02 (DB25 to DB25 interface cable), depending on system requirements.

Field Side - Signal

On the field side a temperature sensor is mounted underneath the field side terminal block to provide cold junction compensation for thermocouple input modules. A current-to-voltage conversion resistor (P/N SCM7BXR1, supplied with SCM7B33 modules) socket is provided for each channel. Field connections are terminated with three screw terminals at each module site.

Ordering Information

Part Number	Description
SCM7BP04	4-channel backpanel with standoffs for mounting.
SCM7BP04-DIN	4-channel backpanel with DIN rail mounting clips. Shipped fully assembled.
SCM7BP08	8-channel backpanel with standoffs for mounting.
SCM7BP08-DIN	8-channel backpanel with DIN rail mounting clips. Shipped fully assembled.
SCM7BP16	16-channel backpanel with standoffs for mounting.
SCM7BP16-DIN	16-channel backpanel with DIN rail mounting clips. Shipped fully assembled.

Specifications

Operating Temperature	-40°C to +85°C
Relative Humidity	95% Noncondensing
Interface Connector:	
Field	high density screw clamp, 10-24 AWG
System	2 DB25 (male) connectors with 4-40 screwlocks
Isolation:	
Input-to-Output	1500Vrms continuous, max
Channel-to-Channel	1500Vrms continuous, max

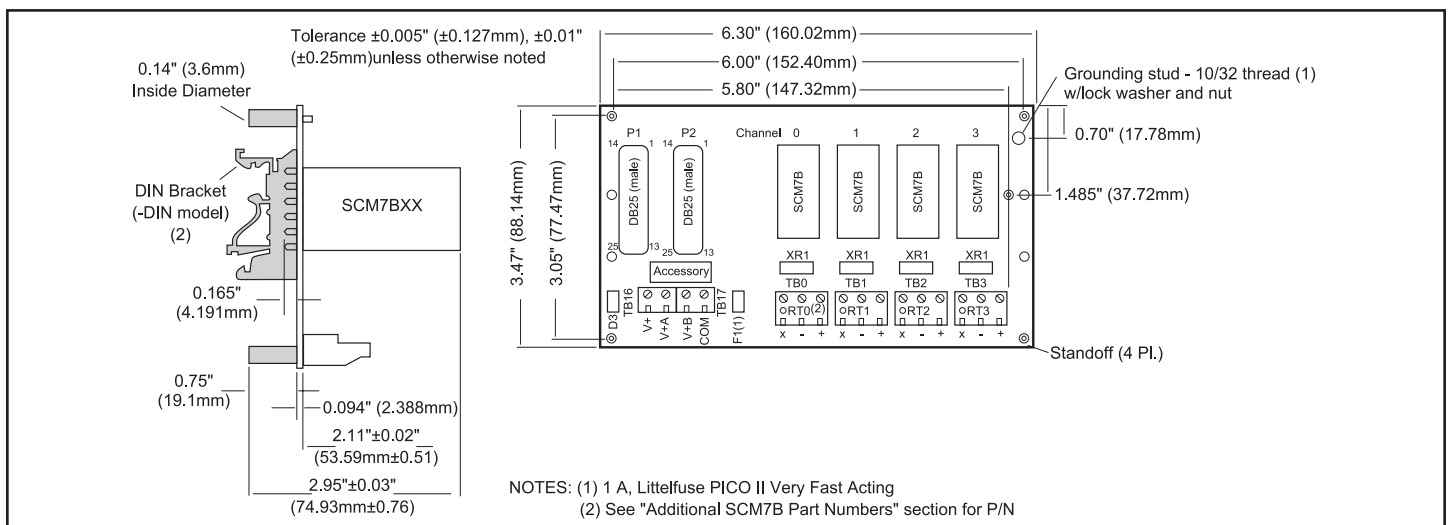

Figure 8: SCM7BP04(-DIN) Dimensions

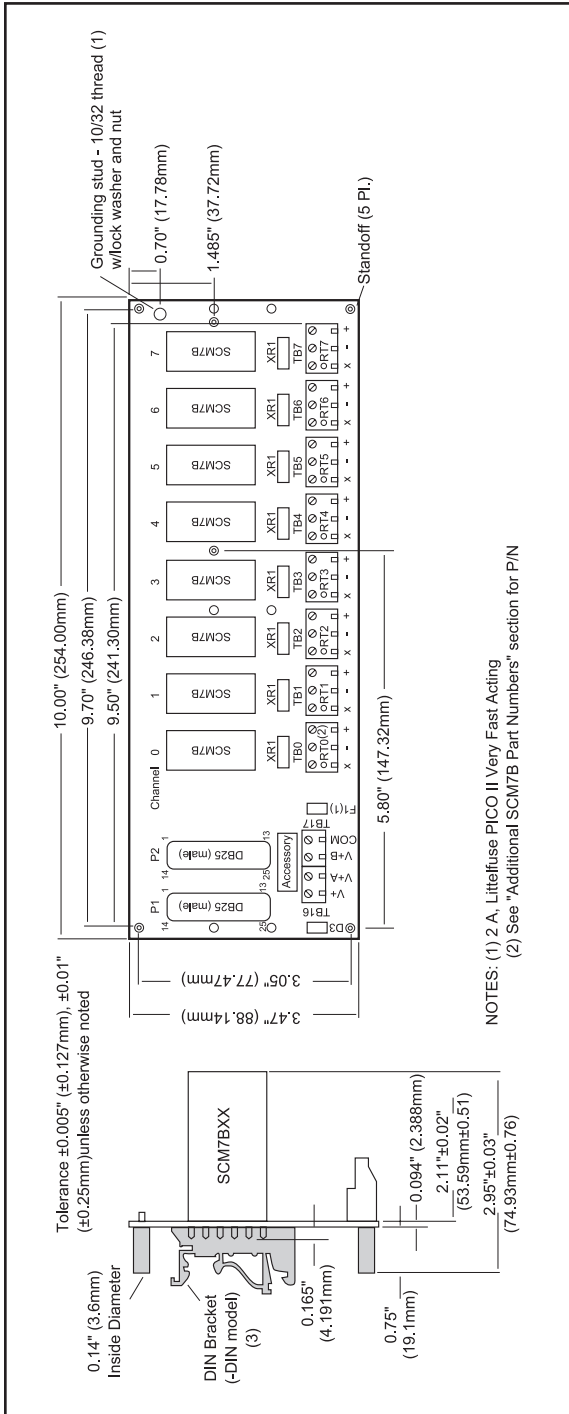

Figure 9: SCM7BP08(-DIN) Dimensions

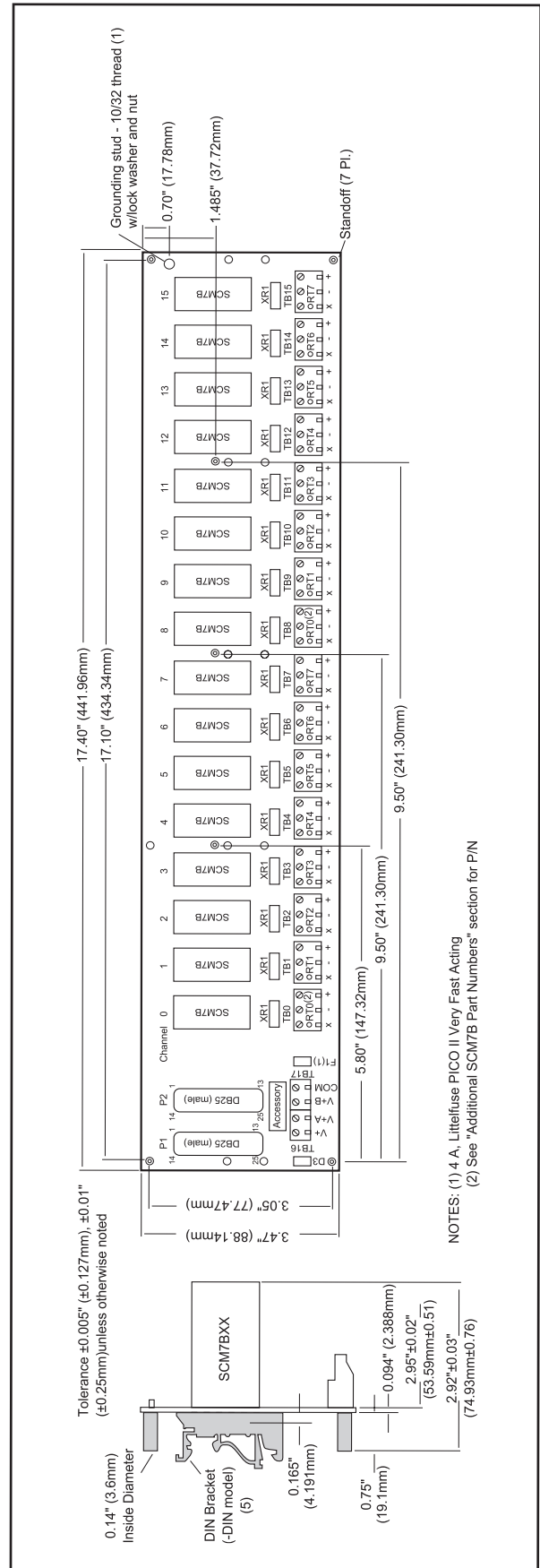

Figure 10: SCM7BP16(-DIN) Dimensions

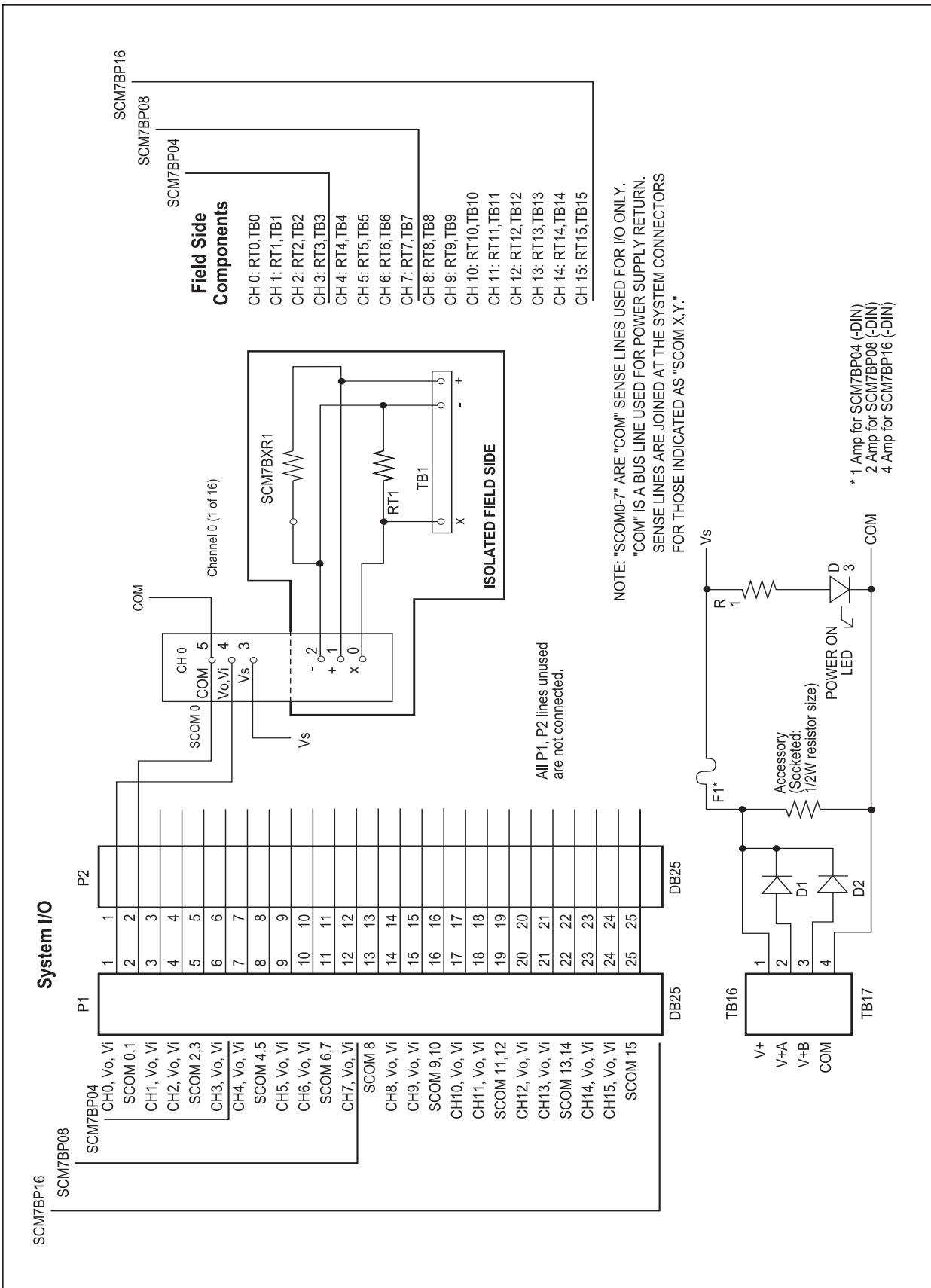

Figure 11: SCM7BP04/08/16(-DIN) Schematic Diagram

SCMXRK-002 19-Inch Metal Mounting Rack

Description

The SCMXRK-002 is a 19-inch metal rack for mounting the SCM7BP04/08/16, SCMPB01/02/05/06, SCMVAS-PB8/PB16, and isoLynx® SLX200-xx backpanels. It also provides capability to mount a system power supply and the universal interface board, P/N SCMXIF. (See Figure 12 for dimensions.)

SCM7B

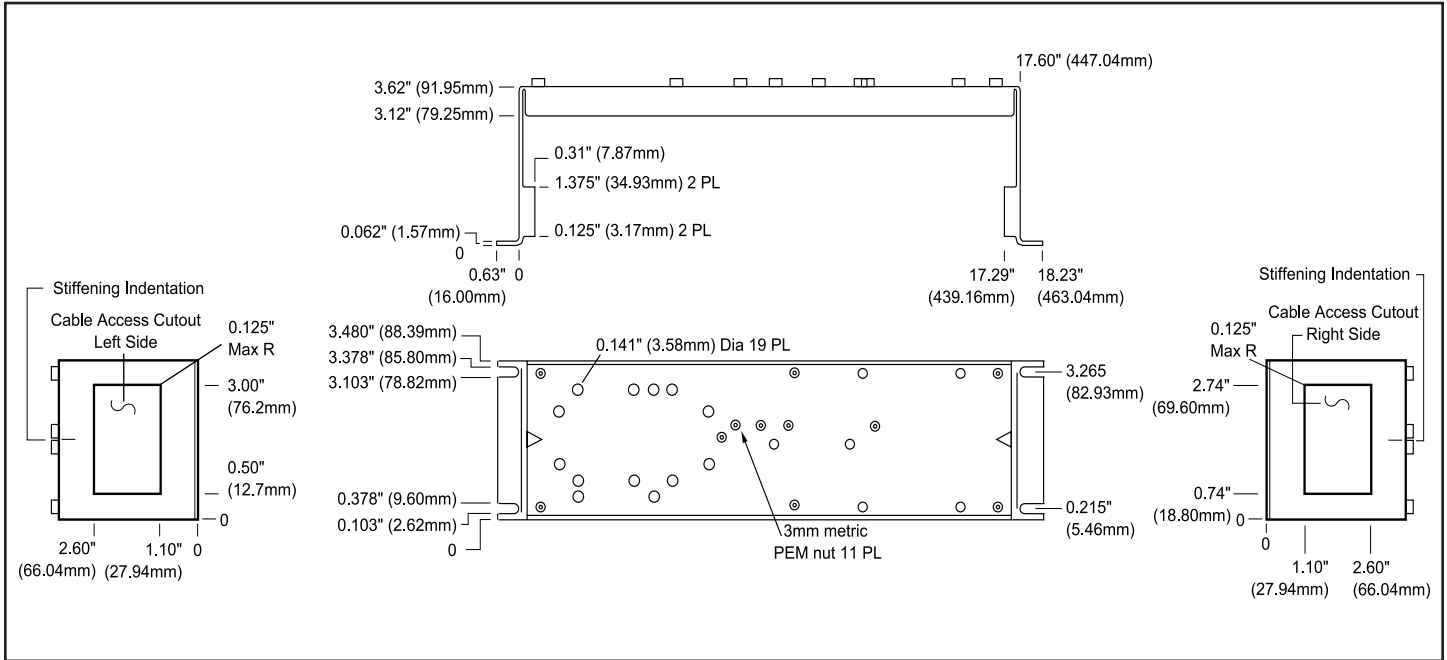

Figure 12: SCMXRK-002 Analog Rack Dimensions

SCMXCA006-01, -02, -07

Interface Cables

Description

SCMXCA006-XX

System interface cable for the SCM7BP04/08/16 backpanels. This is a DB25 Male/Female cable assembly. It can be ordered in lengths of 1m, 2m, and 7m (see Figure 13).

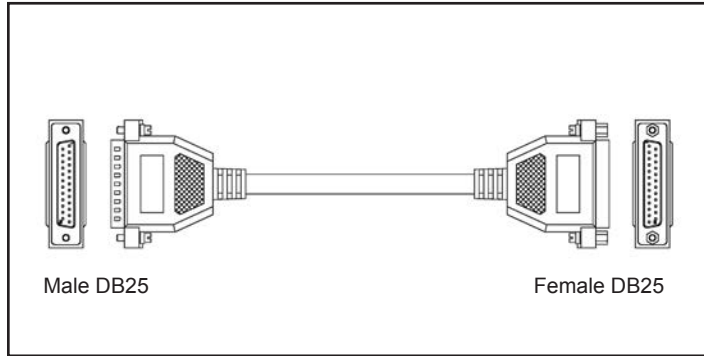

Figure 13: SCMXCA006-XX System Interface Cable

8BXIF (-DIN)

Universal Interface Board

Description

The 8BXIF is a universal interface board which converts a DB25 cable input to 25 screw terminals for discrete wire. It can be mounted on the back of the SCM7XRK-002 mounting rack (8BXIF) or on a DIN rail (8BXIF-DIN). Required mounting hardware is included. Use SCMXCA006-XX cable (see Figure 14 for dimensions).

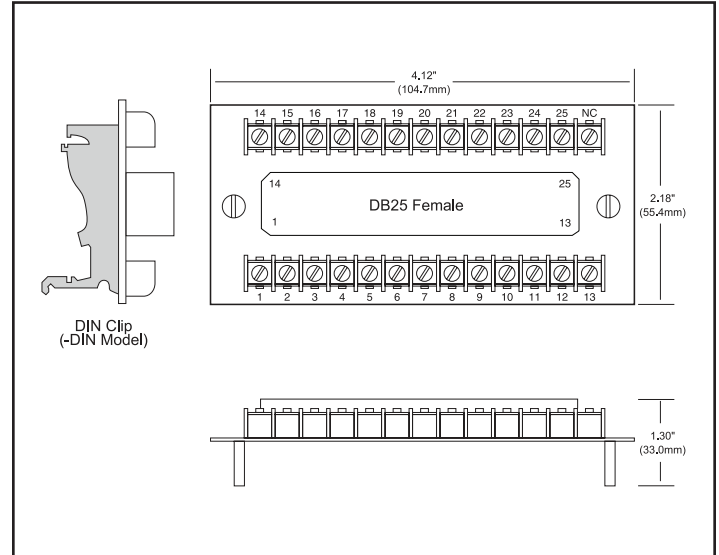

Figure 14: 8BXIF Universal Interface Board Dimensions

SCM7BXR1

Current Conversion Resistor



Description

The SCM7BXR1 current-to-voltage conversion resistor (250Ω, 0.1%, 10ppm) is used with the SCM7B33 voltage input modules. Sockets are provided on all backpanels to allow installation of this resistor. Other values are available; consult the factory for ordering details and specifications.

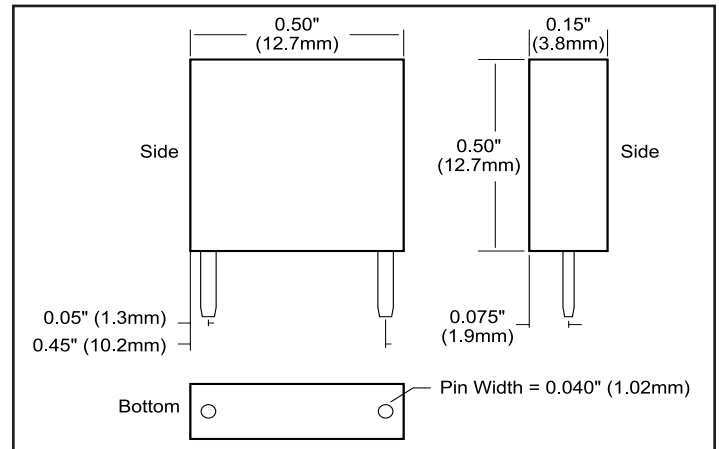

Figure 15: SCM7BXR1 Dimensions